

<b>DTC</b>	<b>P2430</b>	<b>SECONDARY AIR INJECTION SYSTEM AIR FLOW/PRESSURE SENSOR CIRCUIT BANK1</b>
<b>DTC</b>	<b>P2431</b>	<b>SECONDARY AIR INJECTION SYSTEM AIR FLOW/PRESSURE SENSOR CIRCUIT RANGE/PERFORMANCE BANK1</b>
<b>DTC</b>	<b>P2432</b>	<b>SECONDARY AIR INJECTION SYSTEM AIR FLOW/PRESSURE SENSOR CIRCUIT LOW BANK1</b>
<b>DTC</b>	<b>P2433</b>	<b>SECONDARY AIR INJECTION SYSTEM AIR FLOW/PRESSURE SENSOR CIRCUIT HIGH BANK1</b>

**CIRCUIT DESCRIPTION**

To accelerate the activation of catalyst when warming up the engine, the air injection system pumps the secondary air to the exhaust manifold. The secondary air is supplied by the air pump and it is pumped to the exhaust manifold through the air switching valve. Open and close movement of the air switching valve is regulated by the vacuum switching valve (VSV). The air pump and the air switching valve are observed by the ECM and are used to detect malfunction in this system.

The ECM monitors the secondary air injection system and detects malfunction using a pressure sensor located on the air switching valve.

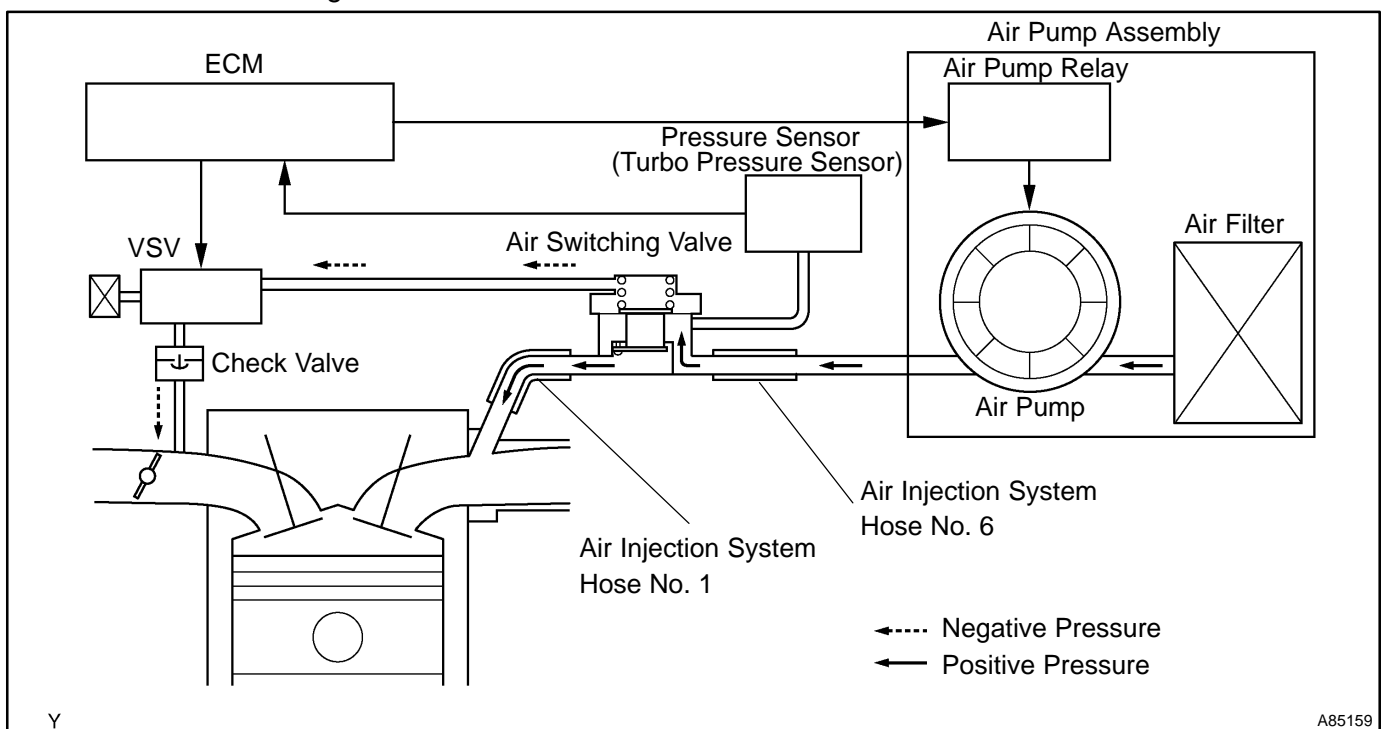

DTC No.	DTC Detecting Condition	Trouble Area
P2430	While the engine is running, if voltage output of the pressure sensor indicates 0.1V or less, or indicates 4.8V or more	<ul style="list-style-type: none"> <li>• Pressure sensor</li> <li>• Open or short in pressure sensor circuit</li> <li>• Vacuum hose</li> <li>• Check valve</li> <li>• ECM</li> </ul>
P2431	The pressure sensor indicates less than 45 kPa (338 mHg), or more than 135 kPa (1013 mHg)	
P2432	While the engine is running, if voltage output of pressure sensor remains below 0.1V	
P2433	While the engine is running, if voltage output of the pressure sensor remains above 4.8V	

## MONITOR DESCRIPTION

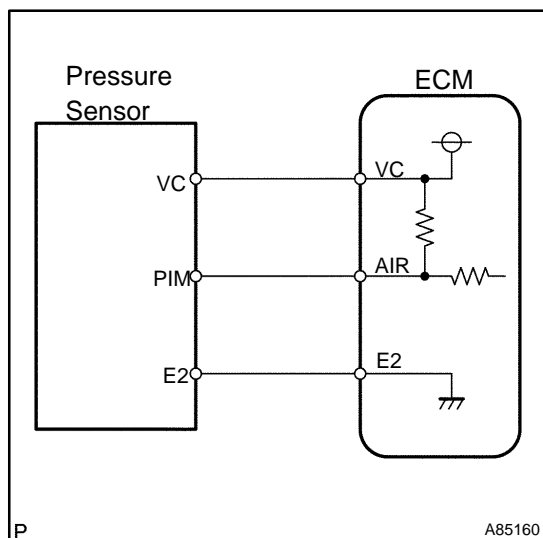

The ECM observes the pressure in the secondary air passage using the pressure sensor located on the air switching valve in the secondary air injection system.

If there is a defect in the sensor or the sensor circuit, the voltage level will deviate from the normal operating range, the ECM interprets this deviation as a defect in the pressure sensor circuit and sets a DTC.

## MONITOR STRATEGY

Related DTCs	P2430	Air flow/Pressure sensor circuit range check (Fluttering)
	P2431	Air flow/Pressure sensor circuit rationality
	P2432	Air flow/Pressure sensor circuit range check (Low voltage)
	P2433	Air flow/Pressure sensor circuit range check (High voltage)
Required sensors/components	Pressure sensor	
Frequency of operation	Continuous	
Duration	0.5 second	
MIL operation	P2430, P2432, P2433: Immediately P2431: 2 driving cycles	
Sequence of operation	None	

### TYPICAL ENABLING CONDITIONS

Item	Specification	
	Minimum	Maximum
The monitor will run whenever the following DTCs are not present	See "List of disable a Monitor" (on page 05-316)	
Starter	OFF	
Time after starter from ON to OFF	2 seconds	-

### TYPICAL MALFUNCTION THRESHOLDS

Detection Criteria	Threshold
<b>P2430:</b>	
Air pressure sensor voltage	Less than 0.1 V, or more than 4.8 V
<b>P2432:</b>	
Air pressure sensor voltage	Less than 0.1V
<b>P2433:</b>	
Air pressure sensor voltage	More than 4.8 v
<b>P2431:</b>	
Air Pressure	Less than 45 kPa (338 mmHg), or more than 135 kPa (1013 mmHg)

### COMPONENT OPERATING RANGE

Parameter	Standard value
Air pressure sensor voltage	Between 0.1 V and 4.8 V

### WIRING DIAGRAM

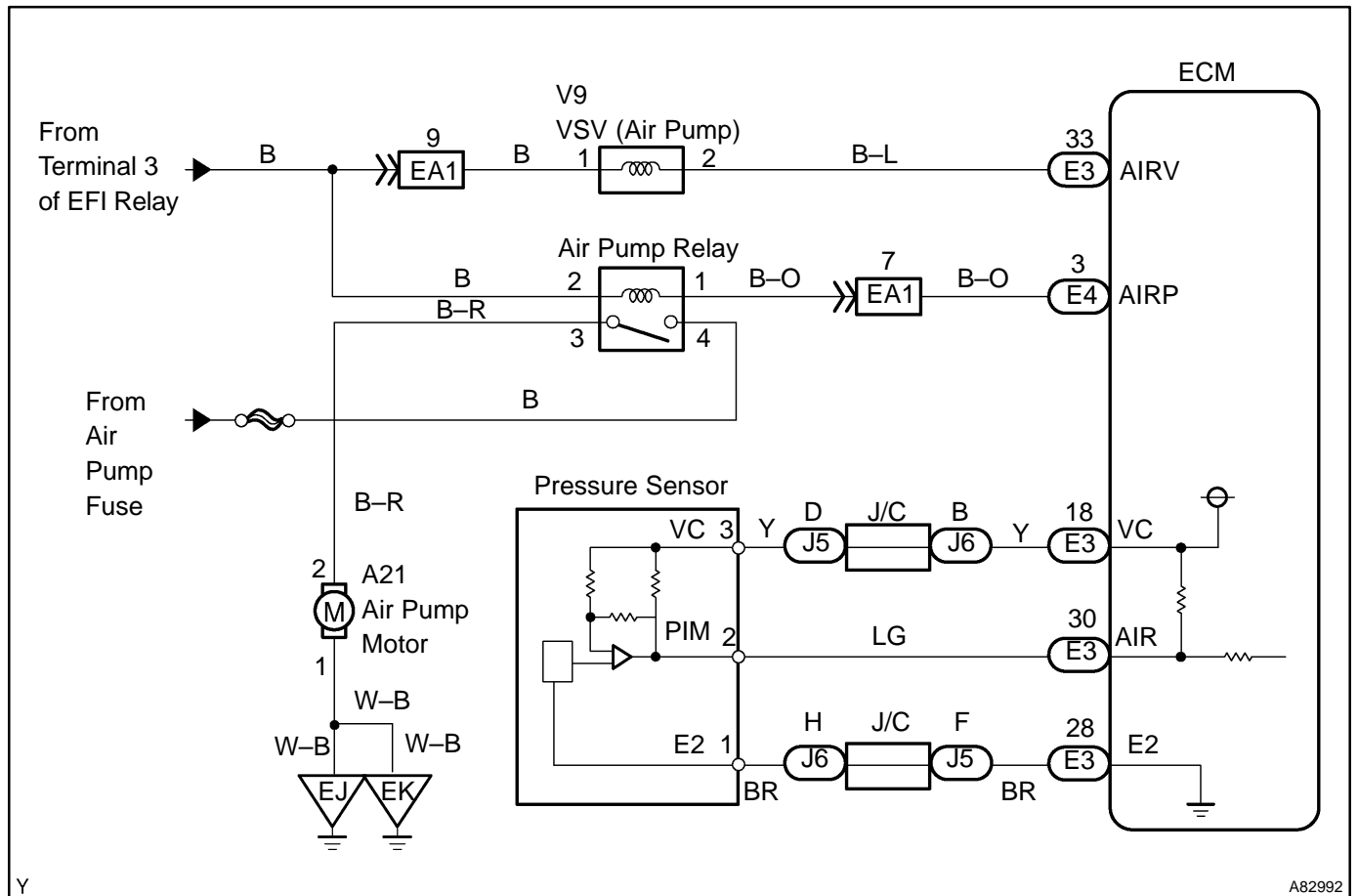

Y

A82992

## INSPECTION PROCEDURE

### HINT:

To check the pressure condition in the secondary air passage, the hand-held tester is available.

- (a) Connect the hand-held tester to the DLC3 on the vehicle.
- (b) Turn the ignition switch ON and push the hand-held tester main switch ON.
- (c) Start the engine.
- (d) Select the item "DIAGNOSIS / ENHANCED OBD II / ACTIVE TEST / SECOND AIR VSV / ALL or USER DATA" (press the right or left button).

### NOTICE:

**When selecting USER DATA, select "SECONDARY AIR" and "SECOND AIR VSV" on the screen by pressing the "YES" button on the tester.**

### HINT:

When operating the VSV in the secondary air system, the air pump is also operated at the same time.

- (e) Check that the SECONDARY AIR, SECOND AIR VSV and 2ND AIR PRESS on the hand-held tester indicate the same conditions as the chart below.

### NOTICE:

**This test allows the technician to operate the VSV for only 5 seconds. If you perform the test again, more than 30 seconds interval must be required after the previous test is done.**

Tester Operation	Specified Condition		2ND AIR PRESS (*3)
	SECONDARY AIR (*1)	SECOND AIR VSV (*2)	
VSV is ON	ON	ON	2.5 kPa or more
VSV is OFF	OFF	OFF	less than 2.5 kPa

### HINT:

\*1: Means the signal output from the ECM to operate the air pump.

\*2: Means the signal output from the ECM to operate the VSV.

\*3: Means the difference between the air pressure inside the air pressure sensor and the atmospheric pressure. When the pressure inside the secondary air injection system is equal to the atmospheric pressure, the hand-held tester displays "0 kPa".

**1 CHECK HARNESS AND CONNECTOR(PRESSURE SENSOR - ECM)**

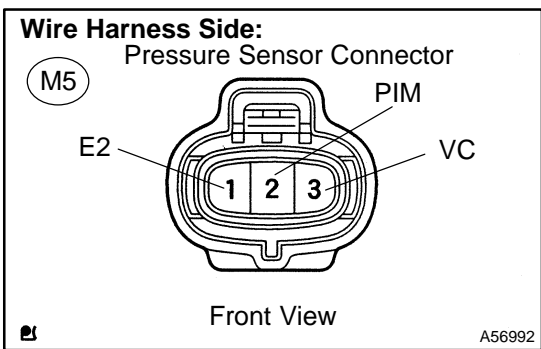

- (a) Disconnect the M5 pressure sensor connector.
- (b) Disconnect the E3 ECM connector.
- (c) Check the resistance between the wire harness side connectors.

**Standard (Check for open):**

Tester Connection	Specified Condition
Pressure sensor (E5-1) - E2 (E3-28)	Below 1 Ω
Pressure sensor (E5-2) - AIR (E3-30)	
Pressure sensor (E5-3) - VC (E3-18)	

**Standard (Check for short):**

Tester Connection	Specified Condition
Pressure sensor (E5-2) or AIR (E3-30) - Body ground	10 kΩ or higher
Pressure sensor (E5-3) or VC (E3-18) - Body ground	

- (d) Reconnect the pressure sensor connector.
- (e) Reconnect the ECM connector.

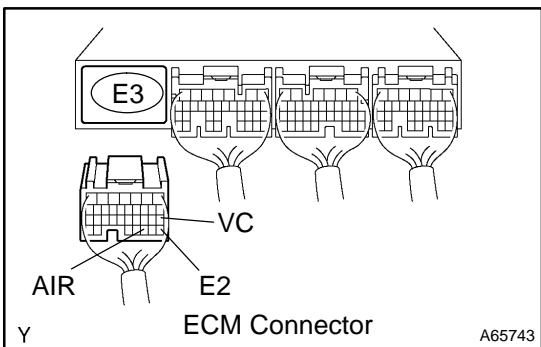

**NG** → **REPAIR OR REPLACE HARNESS AND CONNECTOR**

**OK**

**2 INSPECT ECM(AIP VOLTAGE)**

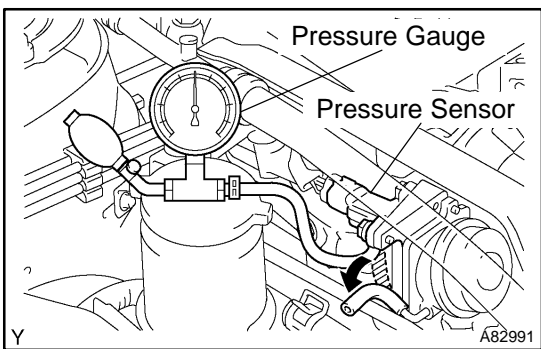

- (a) Connect the pressure gauge to the pressure sensor as shown in the illustration.
- (b) Connect the hand-held tester to the DLC3 on the vehicle.
- (c) Turn the ignition switch ON and push the hand-held tester main switch ON (Do not start engine).
- (d) Select the item "DIAGNOSIS / ENHANCED OBD II / DATA LIST / 2ND AIR PRESS."
- (e) Check that the pressure displayed on the hand-held tester fluctuates when applying the pressure to the pressure sensor with the pressure gauge.

**NG** → **REPLACE PRESSURE SENSOR (TURBO PRESSURE SENSOR) (See page 12-30)**

**OK**

**REPLACE ECM (See page 10-20)**