

Cruise Control

From Power Source System (See Page 54)

- * 1 : 2ZZ-GE
- * 2 : 1ZZ-FE
- * 3 : 1ZZ-FE 2WD
- * 4 : 1ZZ-FE 4WD

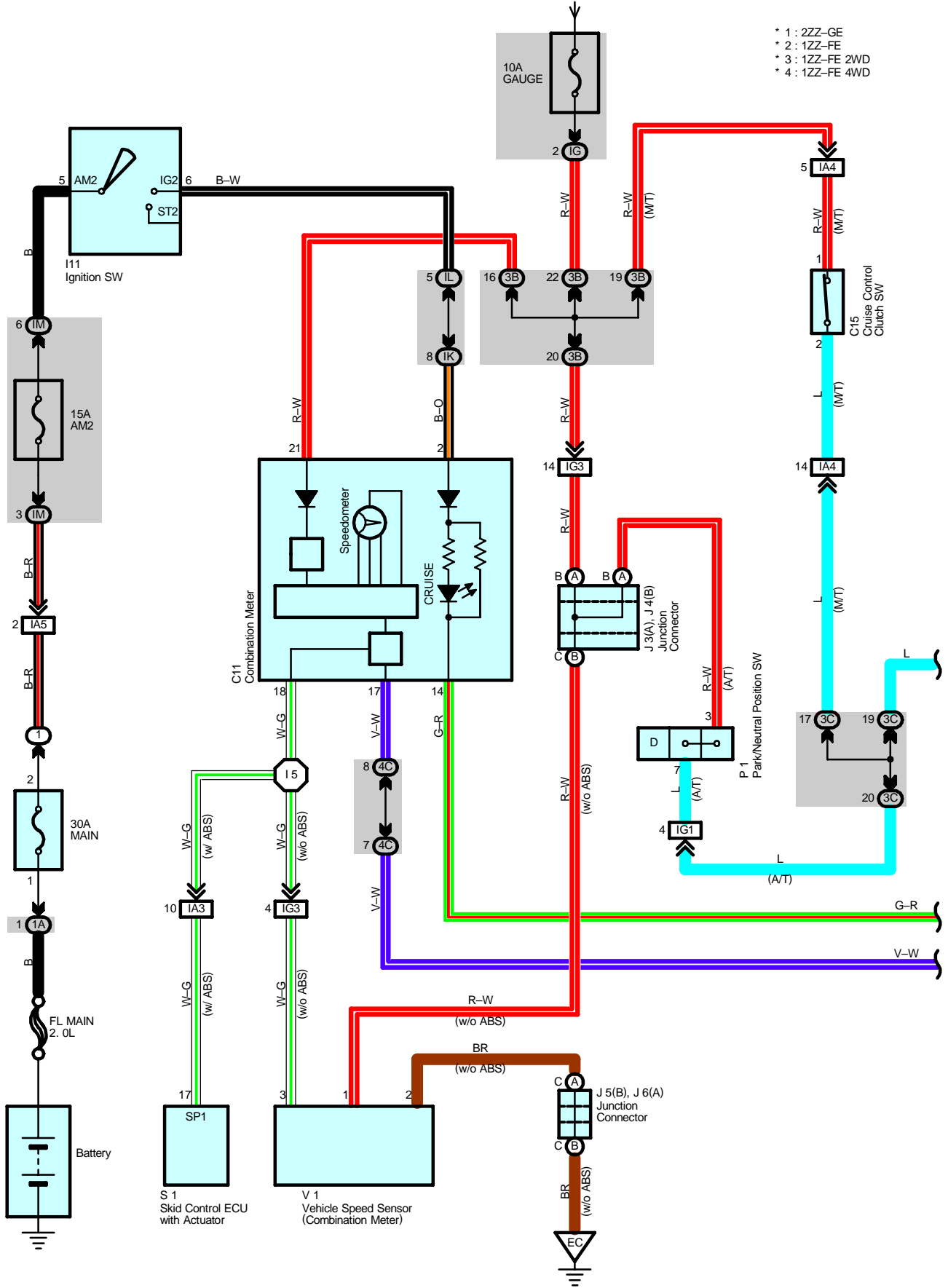

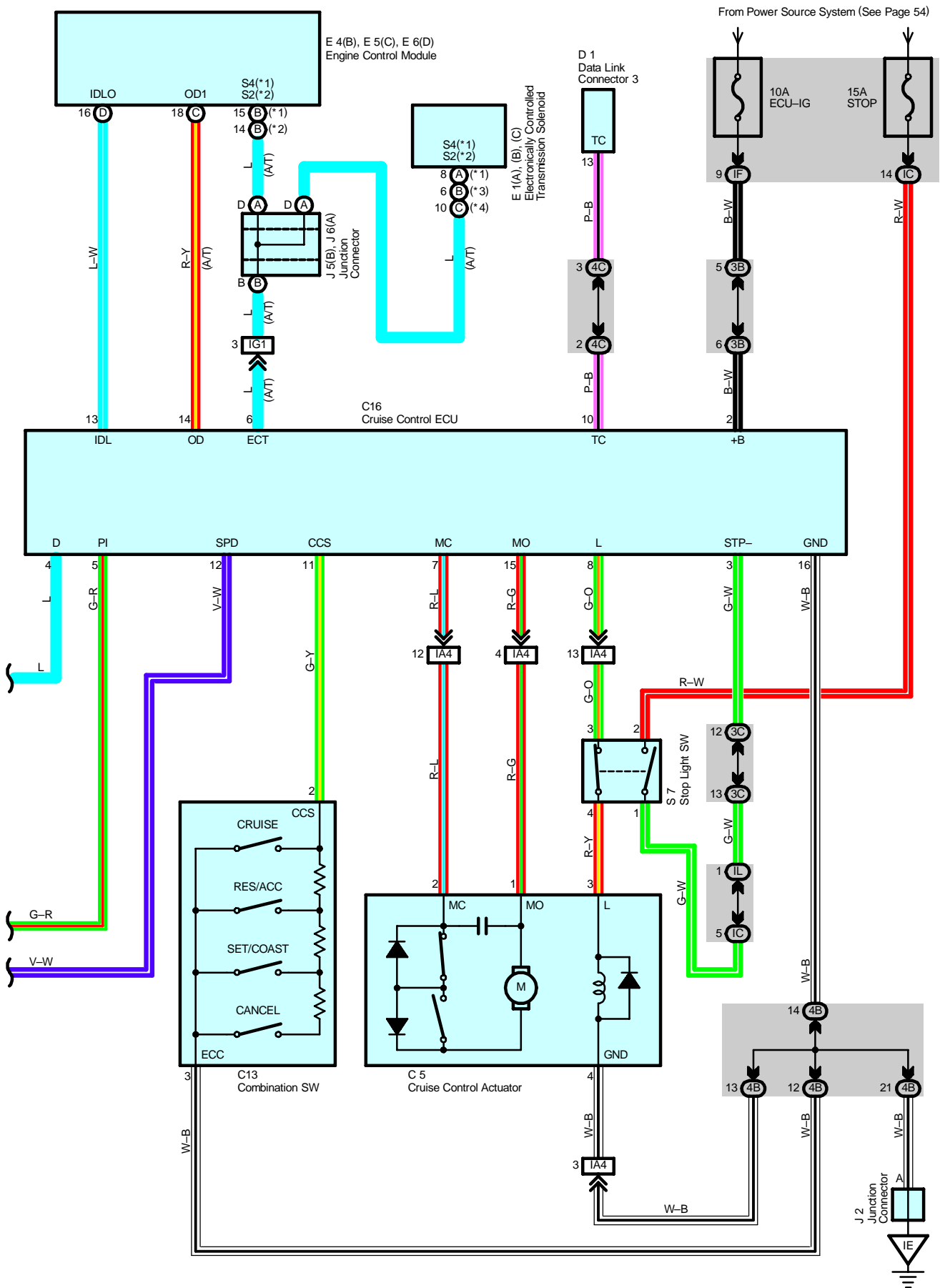

Cruise Control

System Outline

The current is applied at all times through the STOP fuse to TERMINAL 2 of the stop light SW.

With the ignition SW turned on, the current flows through the MAIN fuse to AM2 fuse to ignition SW (IG2) to TERMINAL 2 of the combination meter and the current through the ECU-IG fuse flows to TERMINAL 2 of the cruise control ECU.

When the ignition SW is on and the CRUISE SW is turned on, a signal is input from TERMINAL 2 of the cruise control SW to TERMINAL 11 of the cruise control ECU. As a result, the cruise control ECU functions and the current flows from the ECU-IG fuse to TERMINAL 2 of the cruise control ECU to TERMINAL 16 of the cruise control ECU to GROUND, and the cruise control system is in a condition ready for operation.

At the same time, the current through the MAIN fuse flows to AM2 fuse to ignition SW (IG2) to TERMINAL 2 of the CRUISE indicator light to TERMINAL 14 to TERMINAL 5 of the cruise control ECU to TERMINAL 16 to GROUND, causing the CRUISE indicator light to light up, indicating that cruise control is ready for operation.

1. Set Operation

When the CRUISE SW is turned on and the SET SW is pushed with the vehicle speed within the set limit (Approx. 40 km/h, 25 mph to 200 km/h, 124 mph), a signal is input to TERMINAL 11 of the cruise control ECU, and the vehicle speed at the time the SET SW is released is memorized in the ECU as the set speed.

2. Set Speed Control

During cruise control driving, the ECU compares the set speed memorized in the ECU with the actual vehicle speed input into TERMINAL 12 of the cruise control ECU from the combination meter, and controls the cruise control actuator to maintain the set speed.

When the actual speed is lower than the set speed, the ECU causes the current to the cruise control actuator to flow from TERMINAL 15 of the cruise control ECU to TERMINAL 1 of the cruise control actuator to TERMINAL 2 to TERMINAL 7 of the cruise control ECU. As a result, the motor in the cruise control actuator is rotated to open the throttle valve and the throttle cable is pulled to increase the vehicle speed. When the actual driving speed is higher than the set speed, the current to the cruise control actuator flows from TERMINAL 7 of the ECU to TERMINAL 2 of the cruise control actuator to TERMINAL 1 to TERMINAL 15 of the cruise control ECU.

This causes the motor in the cruise control actuator to rotate to close the throttle valve and return the throttle cable to decrease the vehicle speed.

3. Coast Control

During cruise control driving, while the COAST SW is on, the cruise control actuator returns the throttle cable to close the throttle valve and decrease the driving speed. The vehicle speed when the COAST SW is turned off is memorized, and the vehicle continues at the new set speed.

4. Accel Control

During cruise control driving, while the ACC SW is turned on, the cruise control actuator pulls the throttle cable to open the throttle valve and increase the driving speed.

The vehicle speed when the ACC SW is turned off is memorized and the vehicle continues at the new set speed.

5. Resume Control

Unless the vehicle speed falls below the minimum speed limit (Approx. 40km/h, 25mph) after canceling the set speed by the CANCEL SW, pushing the RES SW will cause the vehicle to resume the speed set before cancellation.

6. Manual Cancel Mechanism

If any of the following operations occurs during cruise control operation, the magnetic clutch of the actuator turns off and the motor rotates to close the throttle valve and the cruise control is released.

- * Placing the shift lever to positions except "D" position (Park/Neutral position SW except "D" position)(A/T), depressing the clutch pedal (Cruise control clutch SW off)(M/T). "Signal is not input to TERMINAL 4 of the ECU"
- * Depressing the brake pedal (Stop light SW on). "Signal input to TERMINAL 3 of the ECU"
- * Pushing the CANCEL SW (CANCEL SW on). "Signal input to TERMINAL 11 of the ECU"
- * Pushing the CRUISE SW off "signal input to TERMINAL 11 of the ECU".

7. Tap-Up Control Function

When the difference between the actual vehicle speed and the set speed is less than 5 km/h (3 mph), the set speed can be increased 1.6 km/h (1 mph) each time by operating the RES/ACC SW quickly within 0.6 seconds.

8. Tap-Down Control Function

When the difference between the actual vehicle speed and the set speed is less than 5 km/h (3 mph), the set speed can be lowered 1.6 km/h (1 mph) each time by operating the SET COAST SW quickly within 0.6 seconds.

9. Auto Cancel Function

A) If any of the following operating conditions occurs during cruise control operation, the set speed is erased, current flow to the magnetic clutch is stopped and the cruise control is released, (CRUISE SW turns off).

When this occurs, the ignition SW must be turned off once before the CRUISE SW will turn on.

- * When current continues to flow to the motor inside the actuator in the throttle valve "OPEN" direction.
- * The motor does not operate despite the motor drive signal being output.

B) If any of the following operating conditions occurs during cruise control operation, the set speed is erased, current flow to the magnetic clutch is stopped and the cruise control is released. (CRUISE SW turn off).

When this occurs, the cancel state is cleared as the CRUISE SW will turn on again.

- * Over current to transistor driving the motor or the magnetic clutch.
- * Open circuit in the magnetic clutch.
- * Momentary interruption of vehicle speed signal.
- * Short circuit in the cruise control SW.

C) If any of the following conditions occurs during cruise control operation, the set speed is erased and the cruise control is released. (The power to the magnetic clutch is cut off until the SET SW is "ON" again.)

- * When the vehicle speed falls below the minimum speed limit, approx. 40 km/h (25 mph)
- * When power to the cruise control system is momentarily cut off.

10. Automatic Transaxle Control Function (A/T)

* In overdrive. If the vehicle speed becomes lower than the overdrive cut speed (Set speed minus approx. 4 km/h, 2.5 mph) during cruise control operation, such as driving up a hill, the overdrive is released and the power is increased to prevent a reduction in vehicle speed.

* After releasing the overdrive, if the vehicle speed becomes higher than the overdrive return speed (Set speed minus approx. 2 km/h, 1.2 mph) and the ECU judges by the signals from the actuator's potentiometer that the upward slope has finished, the overdrive is resumed after approximately 2 seconds.

* During cruise control driving, the cruise control operation signal is output from the cruise control ECU to the engine control module. Upon receiving this signal, the engine control module changes the shift pattern to normal.

To maintain smooth cruise control operation (on a downward slope etc.), the lock-up release of the transaxle when the idling point of the throttle position is "ON" is forbidden.

Service Hints

C13 Combination SW

- 2-3 : Continuity with the CRUISE SW on
- 2-3 : Approx. 1540 Ω with the CANCEL SW on
- Approx. 240 Ω with the RES/ACC SW on
- Approx. 630 Ω with the SET/COAST SW on

C16 Cruise Control ECU

- 2-Ground : 12 volts with the ignition SW at ON position
- 11-Ground : Approx. 1540 Ω with the CANCEL SW on in the control SW
- Approx. 630 Ω with the SET/COAST SW on in the control SW
- Approx. 240 Ω with the RES/ACC SW on in the control SW
- 16-Ground : Always continuity

○ : Parts Location

Code	See Page	Code	See Page	Code	See Page
C5	34 (2ZZ-GE)	E1	C	36 (1ZZ-FE)	J6 A 39
	36 (1ZZ-FE)	E4	B	38	P1 35 (2ZZ-GE)
C11	38	E5	C	38	
C13	38	E6	D	38	S7 35 (2ZZ-GE)
C15	38	I11		39	
C16	38	J2		39	S7 39
D1	38	J3	A	39	
E1	A 34 (2ZZ-GE)	J4	B	39	
	B 36 (1ZZ-FE)	J5	B	39	

○ : Relay Blocks

Code	See Page	Relay Blocks (Relay Block Location)
1	23	Engine Room R/B (Engine Compartment Left)

Cruise Control

: Junction Block and Wire Harness Connector

Code	See Page	Junction Block and Wire Harness (Connector Location)
IC	25	Engine Room Main Wire and Instrument Panel J/B (Lower Finish Panel)
IF	25	Instrument Panel Wire and Instrument Panel J/B (Lower Finish Panel)
IG		
IK		
IL	24	
IM		
1A	23	Engine Wire and Engine Room J/B (Engine Compartment Left)
3B	29	Instrument Panel Wire and RH J/B (Right Side of the Instrument Panel Reinforcement)
3C		
4B	32	Instrument Panel Wire and Center J/B (Behind the Combination Meter)
4C		

: Connector Joining Wire Harness and Wire Harness

Code	See Page	Joining Wire Harness and Wire Harness (Connector Location)
IA3	46	Engine Room Main Wire and Instrument Panel Wire (Instrument Panel Reinforcement LH)
IA4		
IA5		
IG1	48	Engine Wire and Instrument Panel Wire (Blower Unit RH)
IG3		

: Ground Points

Code	See Page	Ground Points Location
EC	44 (1ZZ-FE)	Left Side of the Cylinder Head
IE	46	Behind Combination Meter

: Splice Points

Code	See Page	Wire Harness with Splice Points	Code	See Page	Wire Harness with Splice Points
I5	48	Instrument Panel Wire			